

KEY FEATURES

Comprehensive GNSS support, including GPS Modernization signals, GLONASS, and Galileo

Rugged Package ideal for vehicle applications

Bulkhead Mounting

Sub-centimeter phase center repeatability

The Trimble AV59 GNSS Antenna has been designed to support centimeter level accuracy on aerial, land and marine applications. The rugged 8 hole bulkhead mounting allows the antenna to be used in the most rugged of environments.

COMPREHENSIVE GNSS SUPPORT

The Trimble AV59 GNSS antenna offers support for present and future GNSS signals, including GPS L5, GLONASS and Galileo. This ensures that the antenna will operate with your present and most likely future GNSS receivers.

ROBUST, LOW-MULTIPATH GPS ANTENNA

The antenna resists unwanted signal interference or multipath, which can cause inaccurate measurements. Multipath is caused by signals being reflected from surfaces such as the ground, surrounding trees, or buildings.

FLEXIBILITY

The antenna is an aviation type of design. The bulkhead mounting ensures only the rugged radome is exposed to the elements. This is an ideal design for customers building machine control systems. The antenna can be mounted flush with the vehicle surface or on the top of a pole mount. The TNC connector is located on the underside of the unit ensuring the attached cable is also protected from the environment.



Trimble AV59 GNSS Antenna

TRIMBLE AV59 GNSS ANTENNA

PERFORMANCE

- Broad GNSS Frequency Tracking Band Including:
 - GPS: L1, L2, L5
 - GLONASS: L1, L2, L3
 - Galileo: E1, E2, E5,
 - SBAS: WAAS, EGNOS, QZSS, Gagan, MSAS, and OmniStar
- Quality signal tracking
- TNC female signal connector
- Small cross-sectional area to reduce wind loading
- Low voltage, low power consumption
- Integral low noise amplifier
- 8 recessed bulkhead mounting holes
- Powered by GNSS receiver via coaxial cable
- Rugged radome designed for machine environments
- High gain for reliable tracking in difficult environments

ELECTRICAL

Signal gain.....39 dB
 Voltage.....4.2 V DC to 15 V DC
 Polarization.....Right Hand Circular
 Axial Ratio.....3 dB Max @ boresight
 Amplifier.....Noise Figure : 2.6 dBMax
 Impedance : 50 Ohms
 VSWR : ≤ 2.0:1

HARDWARE

Dimensions.....14.62 cm diameter x 3.89 cm height
 (5.575 in diameter x 1.53 in height)
 Weight.....0.30 kg (0.67lb)
 Operating Temperature.....-40 °C to +85 °C (-40 °F to +185 °F)
 Finish.....UV resistant white radome with
 aluminum base
 ComplianceROHS

ENVIRONMENTAL QUALIFICATIONS

CONDITIONS	DO-160D SECTION	STRING CATEGORY	DESCRIPTION
Temperature Variation	5	A	-55°C to +85°C, 10%/min, 2 cycles
Humidity	-	Method 507.4	MIL-STD-810-F
Shock	-	Method 516.5	MIL-STD-818-F Procedure II
Vibration	-	Method 514.5C-3	MIL-STD-810-F, Section 514.5-CVII

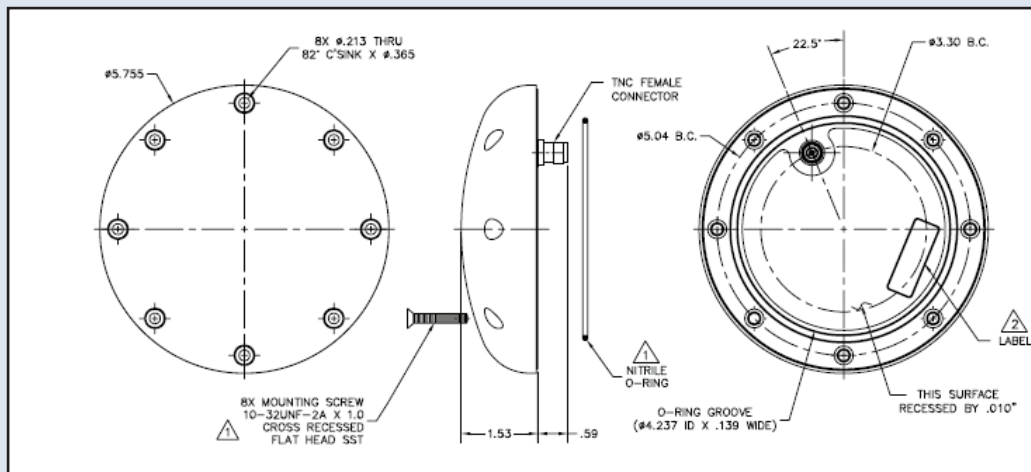

© 2012, Trimble Navigation Limited. All rights reserved. Trimble and the Globe & Triangle logo are trademarks of Trimble Navigation Limited, registered in the United States and in other countries. All other trademarks are the property of their respective owners (02/12)



AMERICAS & ASIA-PACIFIC
TRIMBLE NAVIGATION LIMITED
Integrated Technologies
 510 DeGuigne Drive
 Sunnyvale, CA 94085
 USA
 +1-408-481-8070 Phone
 +1-408-481-8984 Fax
 Email: sales-intech@trimble.com

EUROPE & MIDDLE EAST
TRIMBLE GERMANY GmbH
 Integrated Technologies
 Am Prime Parc
 1165479 Raunheim,
 Germany
 Phone +49 (6142) 177-2135
 Fax +49 (6142) 177-2136
 emeasales-intech@trimble.com

CHINA
TRIMBLE NAVIGATION LIMITED
Integrated Technologies
 311 Fute (M) Road, 3/F
 Wai Gaoqiao Free Trade Zone
 Pudong, Shanghai 200131
 China
 Email: chinasales-intech@trimble.com

RUSSIA
TRIMBLE NAVIGATION LIMITED
Integrated Technologies
 Tel: +7 495 258 5045
 Email: rusales-intech@trimble.com

www.trimble.com/gnss-inertial